

SC 100 Sandmaster

Sandmaster SC 100

Key Features

- 3048mm x 1220mm (10.x4') Reverse slope linear motion dewatering screen
- 2 x 4kW vibrating motors
- 40 Polyurethane panels - 305mm x 305mm (1' x 1')
- Adjustable amplitude
- 610mm (24") hydrocyclone
- 200/150 Centrifugal Slurry Pump complete with 22kW motor
- Sump tank 6800 ltrs (1500 UK Gal / 1800 US Gal)
- Sump tank 4090 lpm (900 UK Gpm / 1080 US gpm) - water requirement
- Output capacity up to 100 tph (dependent on application and type of material)

Dimensions

Transport:	Length	8200mm	(26' 10")
	Width	2600mm	(8' 6")
	Height	3300mm	(10' 10")

Working:	Length	6100mm	(20')
	Width	2600mm	(8' 6")
	Height	6100mm	(20')

Weight

Empty:	7500kgs	(16,534lbs)
Working- Maximum:	28000kgs	(61,729lbs)

Dewatering screen

- VD12 Reverse slope linear motion dewatering screen
- 2x 4kW Vibrating motors
- Direct force screen 3048mm x 1220mm (10' x 4')
- 40 Polyurethane panels- 305mm x 305mm (1' x 1')
- Adjustable amplitude

Cyclone

- Type 624 610mm (24") Hydrocyclone

Pump

- 200/150 Linapump complete with 22kW motor

Capacities

Sump tank: 6800 Litres (1500 UK Gal / 1800 US Gal)

4090 Lit/min (900 UK gpm / 1080 US gpm) – Water requirement

Output Capacity: Up to 100tph (Dependant on application and type of material)

Sandmaster SC 100

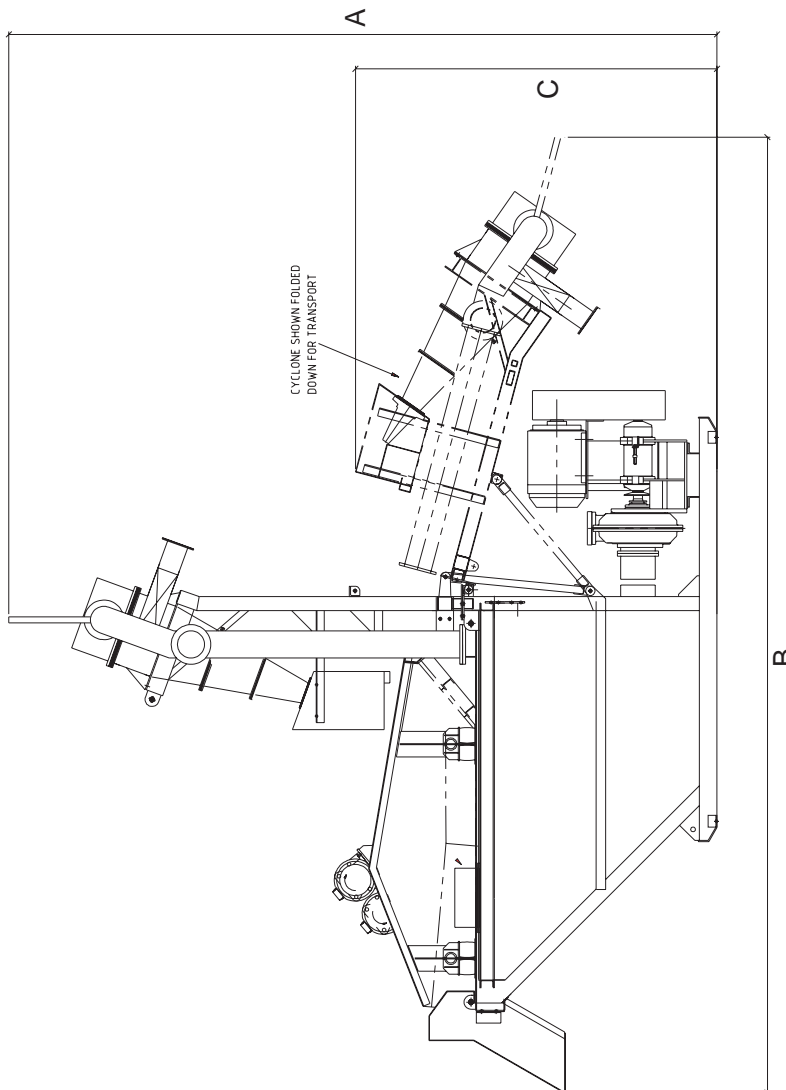
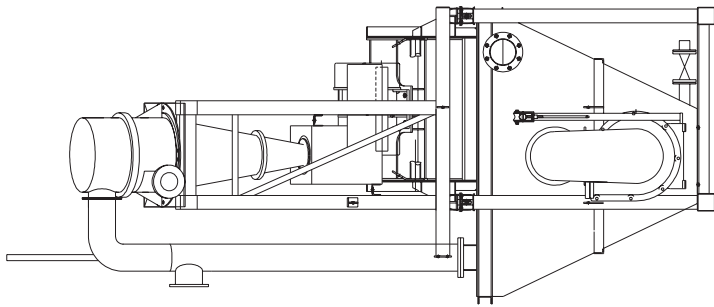

Dimensions- Transport mode

Length (B) : 8200mm (26' 10")
 Width: 2600mm (8' 6")
 Height (C): 3300mm (10' 10")
 Weight: 7500Kgs (16,534 lbs) **
 **Empty weight

Dimensions- Working mode

Length: 6100mm (20')
 Width: 2600mm (8' 6")
 Height (A): 6100mm (20')
 Weight: 28000Kgs (61,729 lbs) *
 *Max working weight

